

RE-ENTRANT CORNERS

10
TYPICAL DETAIL -
PLAN VIEW REINFORCING IN SLAB ON GRADE
NOT TO SCALE

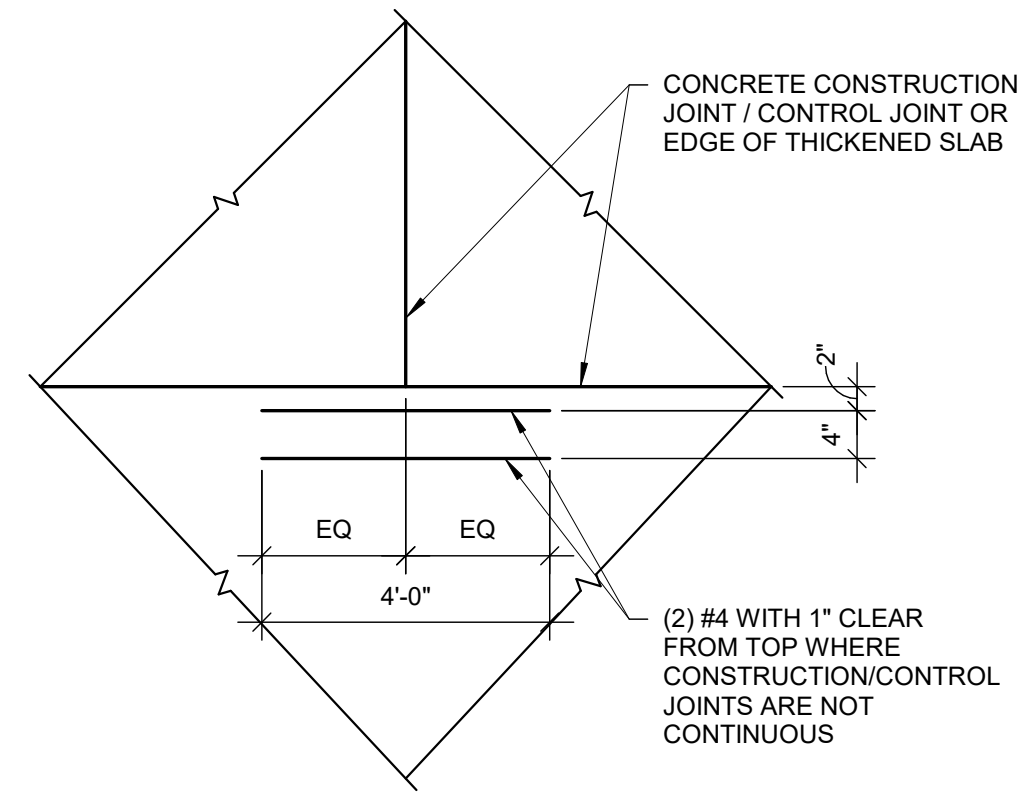

CONSTRUCTION OR CONTROL JOINT INTERSECTION

NOTE:
PROVIDE BOTTOM REINFORCEMENT FOR SLABS GREATER OR EQUAL TO 6" THICK WITH 2" CLEAR FROM BOTTOM

4
TYPICAL DETAIL -
UTILITY BELOW WALL FOOTING
NOT TO SCALE

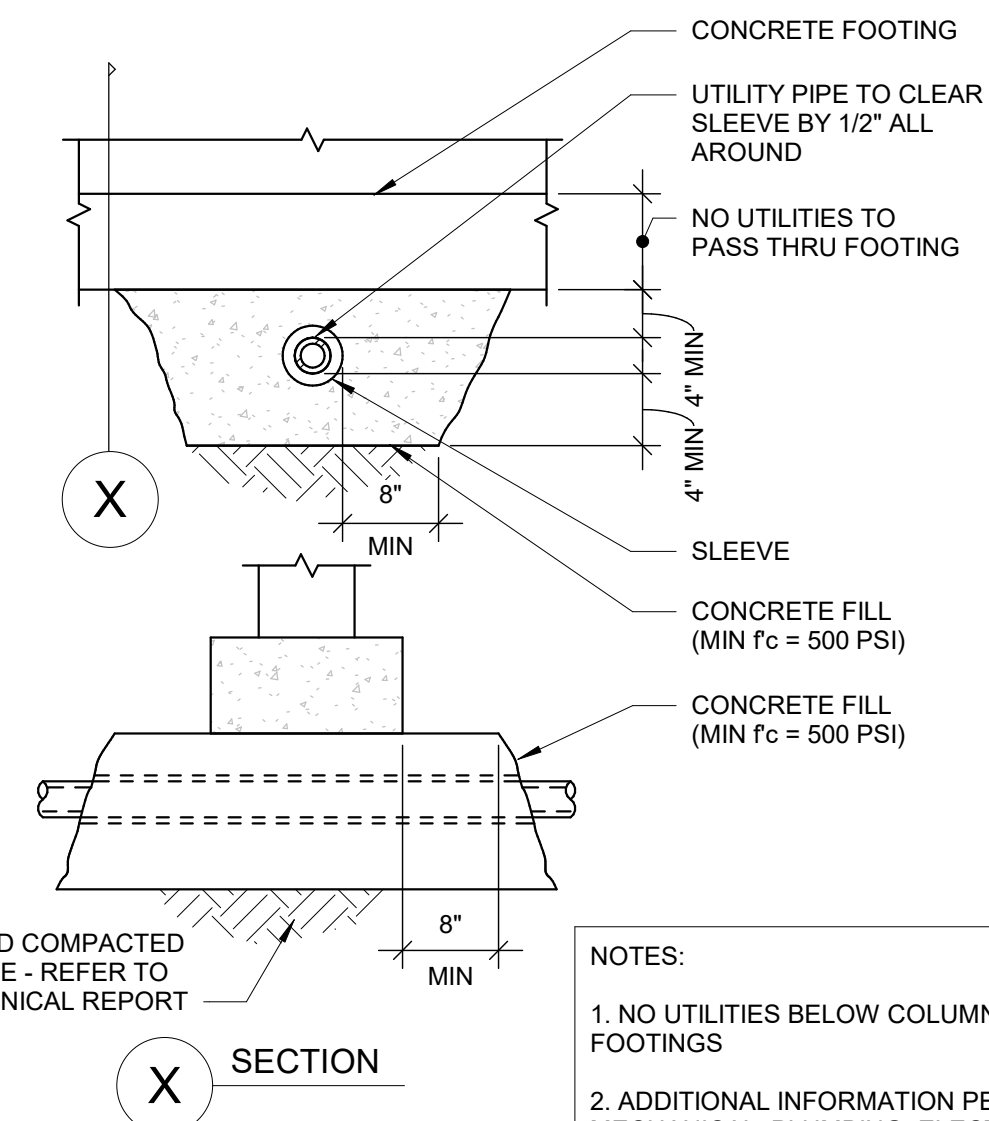

NOTES:
1. NO UTILITIES BELOW COLUMN FOOTINGS
2. ADDITIONAL INFORMATION PER MECHANICAL, PLUMBING, ELECTRICAL, AND CIVIL

4
TYPICAL DETAIL -
UTILITY BELOW WALL FOOTING
NOT TO SCALE

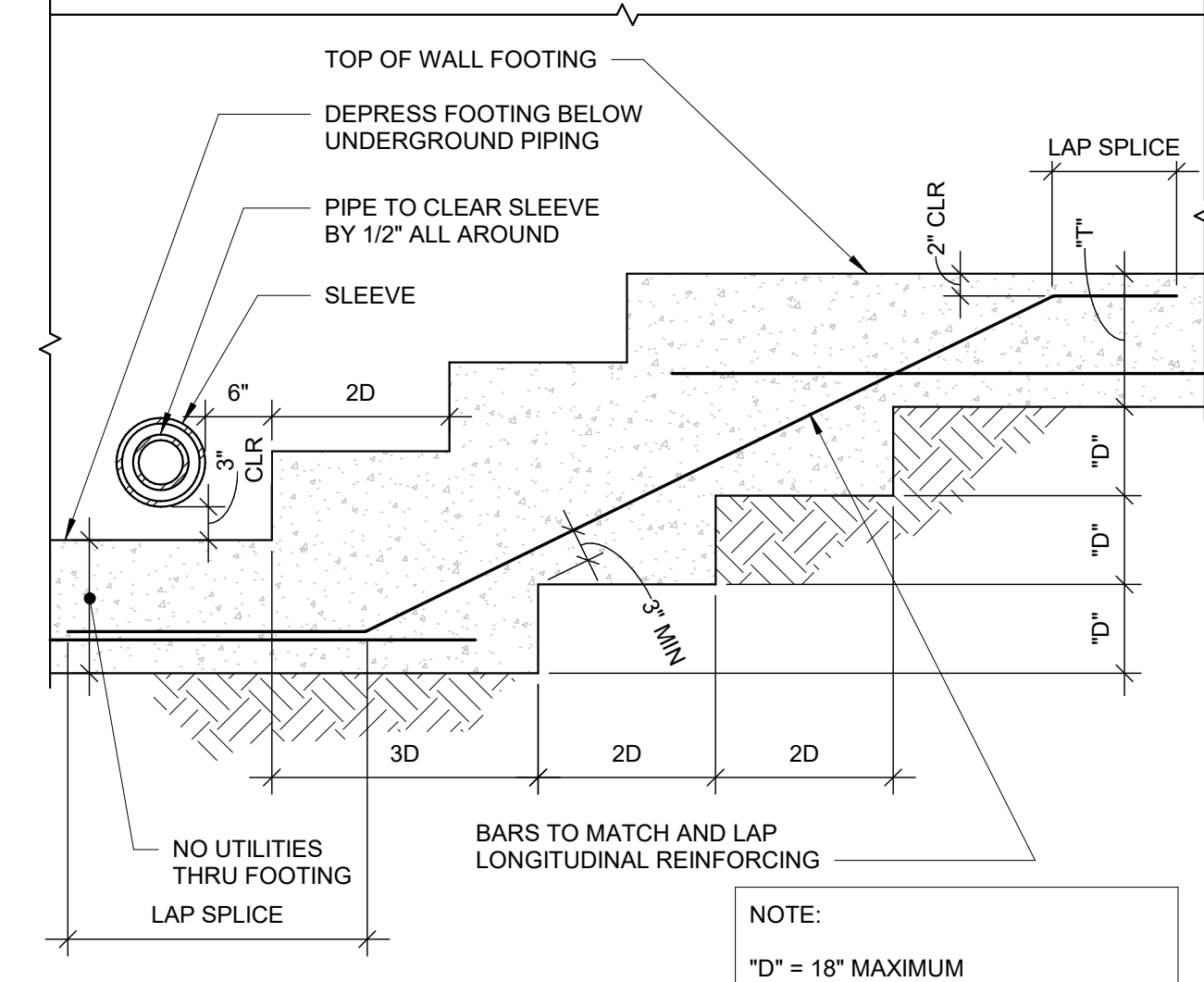

NOTE:
"D" = 18" MAXIMUM

1
TYPICAL DETAIL -
STEPPED FOOTING
NOT TO SCALE

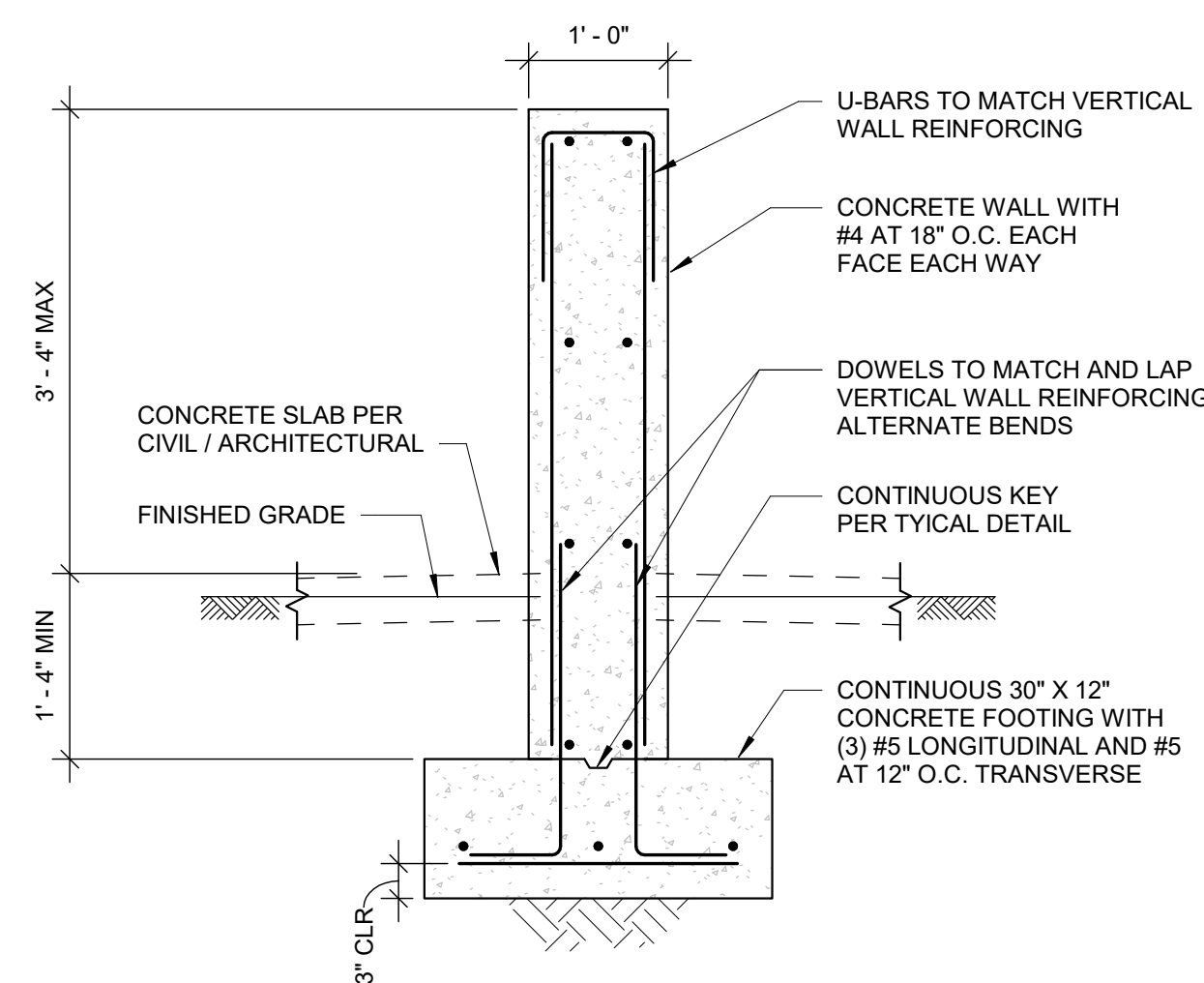

11
TYPICAL DETAIL -
CONCRETE SITE WALL AND FOOTING
NOT TO SCALE

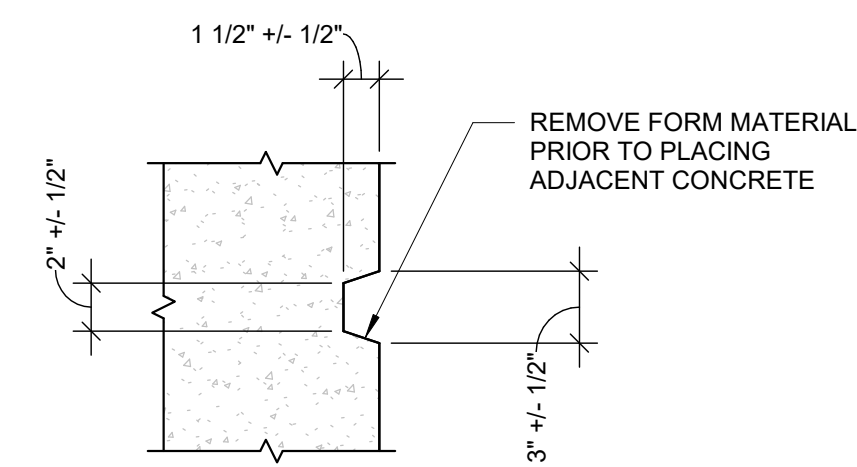

9
TYPICAL DETAIL -
CONCRETE KEY
NOT TO SCALE

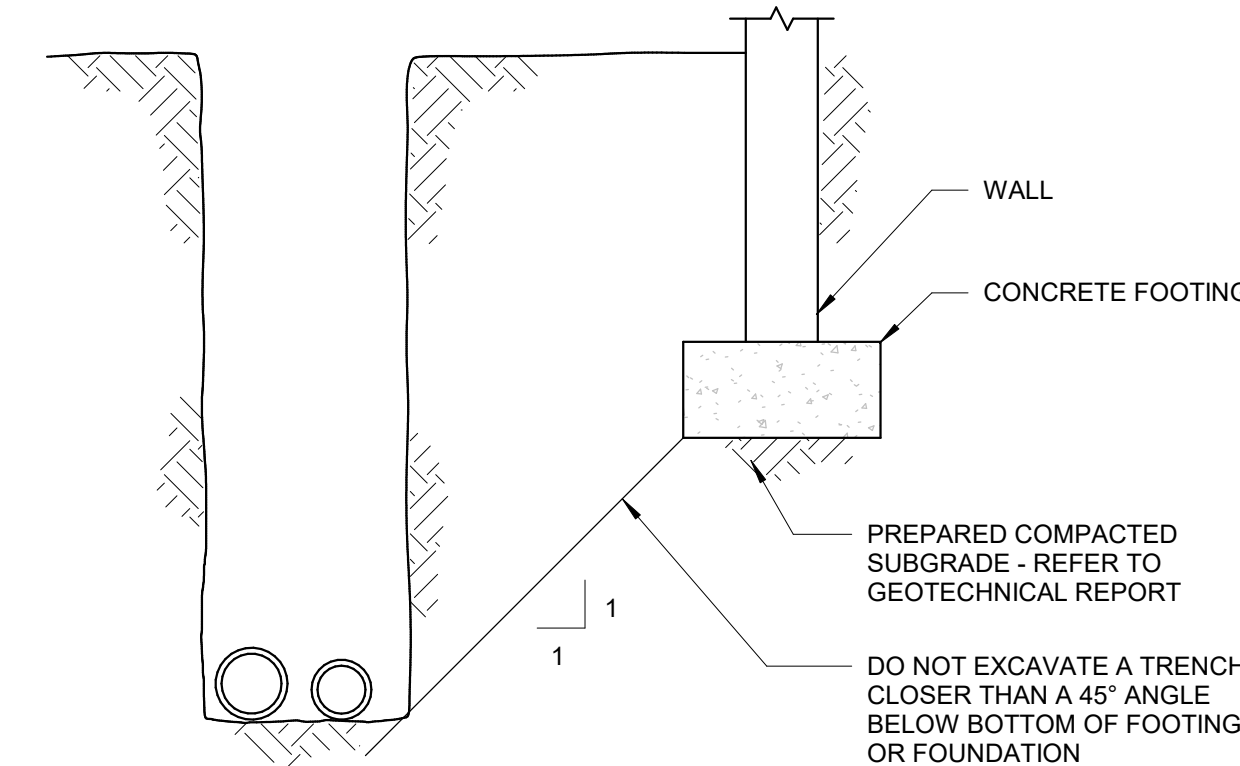

5
TYPICAL DETAIL -
TRENCH ADJACENT TO FOOTING
NOT TO SCALE

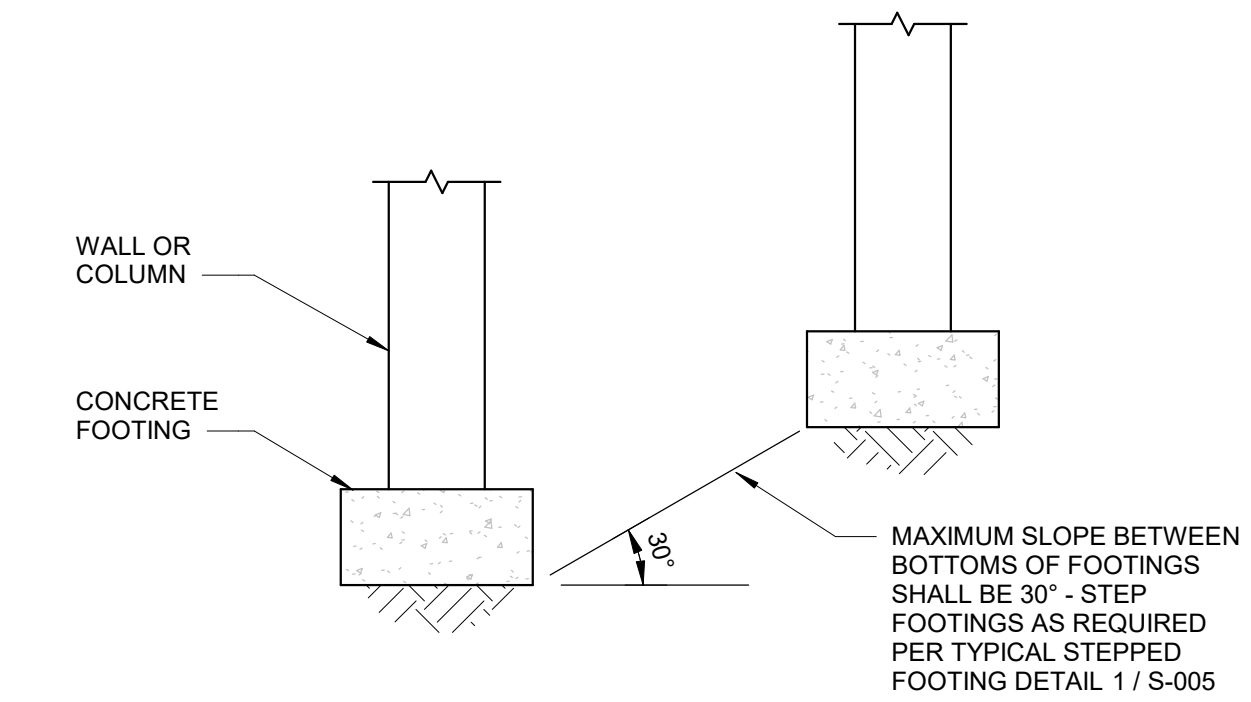

2
TYPICAL DETAIL -
MAXIMUM SLOPE BETWEEN ADJACENT FOOTINGS
NOT TO SCALE

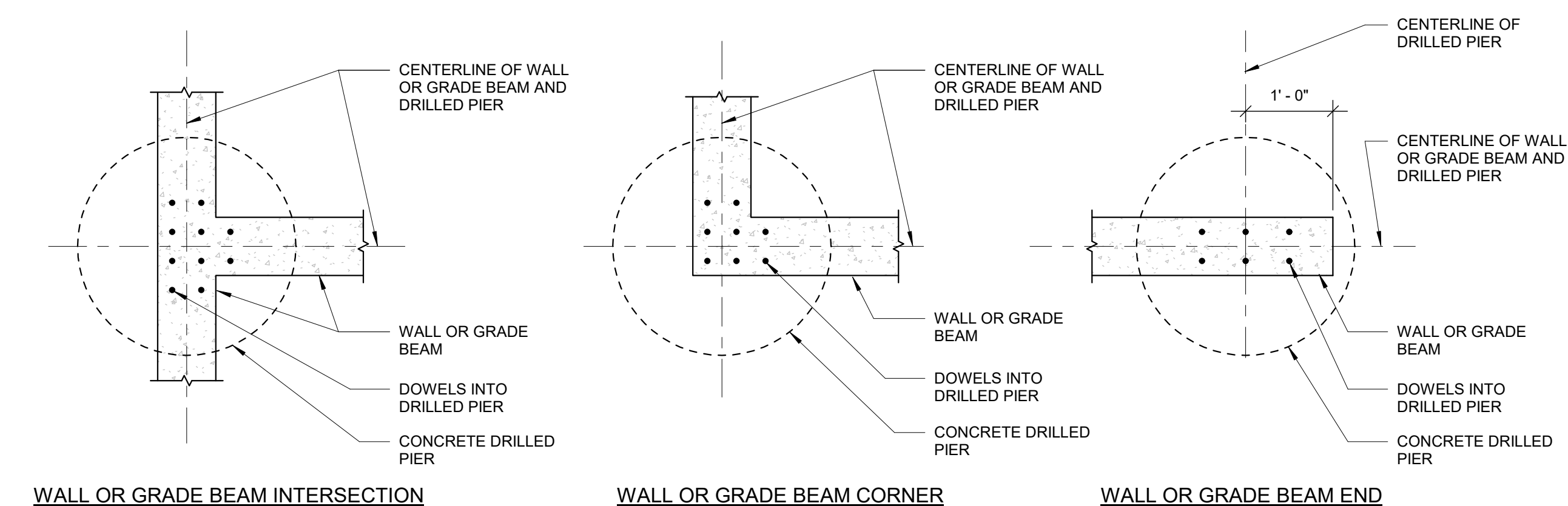

12
TYPICAL DETAIL -
CONCRETE DRILLED PIER LOCATIONS
NOT TO SCALE

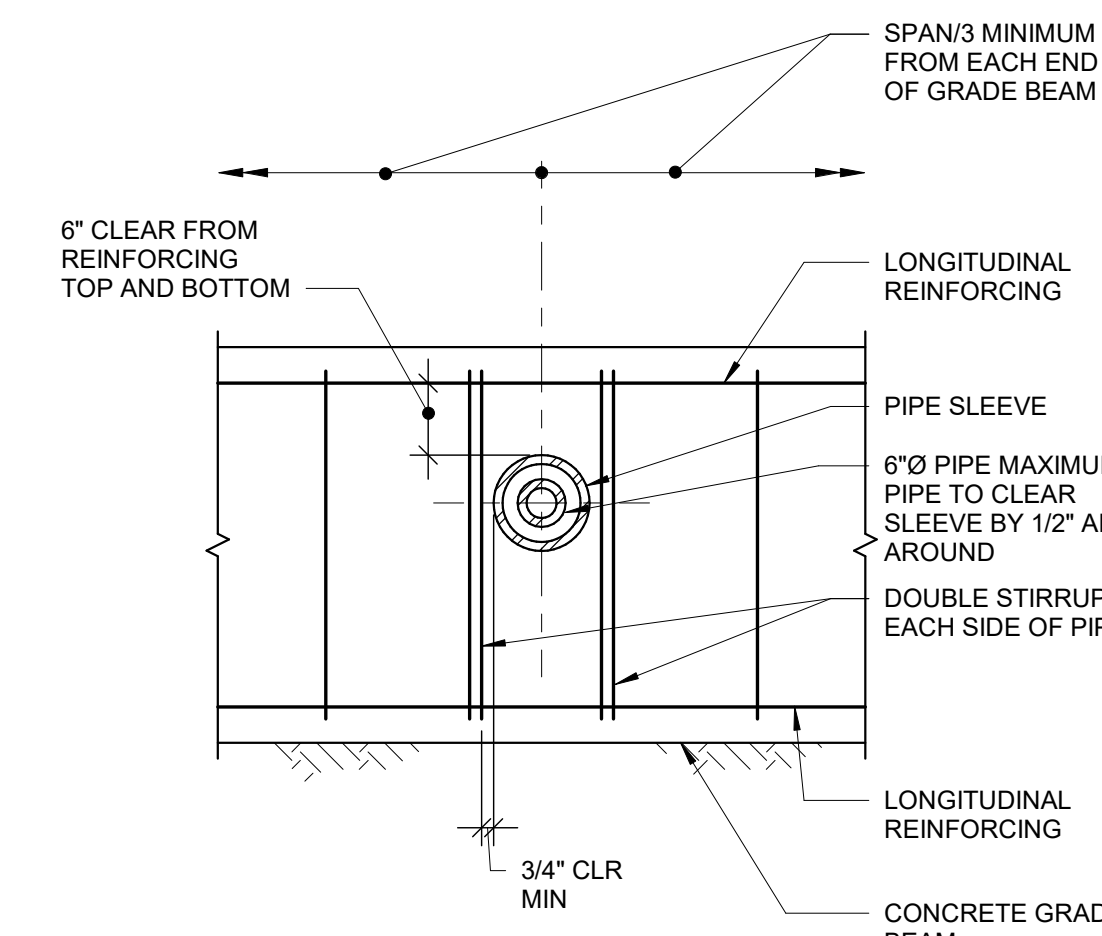

6
TYPICAL DETAIL -
PIPE PENETRATION THRU CONCRETE GRADE BEAM
NOT TO SCALE



Your environmental partner since 1954

UCSB Campus
Parking Lot 32
Santa Barbara, CA 93106
(p) 805 968-2617 (f) 805 562-8987

ADMINISTRATION BUILDING

EDUARDO GALINDO
ARCHITECT

9733 W. SUNNYSLOPE LANE
PEORIA, ARIZONA 85345

480.751.8780 ed@gagedesign.net

egagedesign.net



ISSUED REV DATE
BUILDING PERMIT REVIEW 29 AUG 2023

TYPICAL DETAILS
1 - 15

SCALE 17-036

PROJECT NUMBER

DRAWING NUMBER **S-005**

Kimley»Horn
7740 N 16th St #300, Phoenix, AZ 85020
(602) 944-5500